

## IC-775 ROOFING FILTER INSTALLATION INSTRUCTIONS

The IC-775 roofing filter mod consists of a 6 pole, 5 kHz wide filter followed by a high dynamic range, feedback amplifier. The amplifier provides enough gain to override the filter insertion loss plus a few dB.

The plot below shows the sweep frequency response of the RF board in an IC-775 radio. The wider curve is the OEM response and the narrow curve is with the Inrad roofing filter mod added. The improvement in first IF selectivity is dramatic.

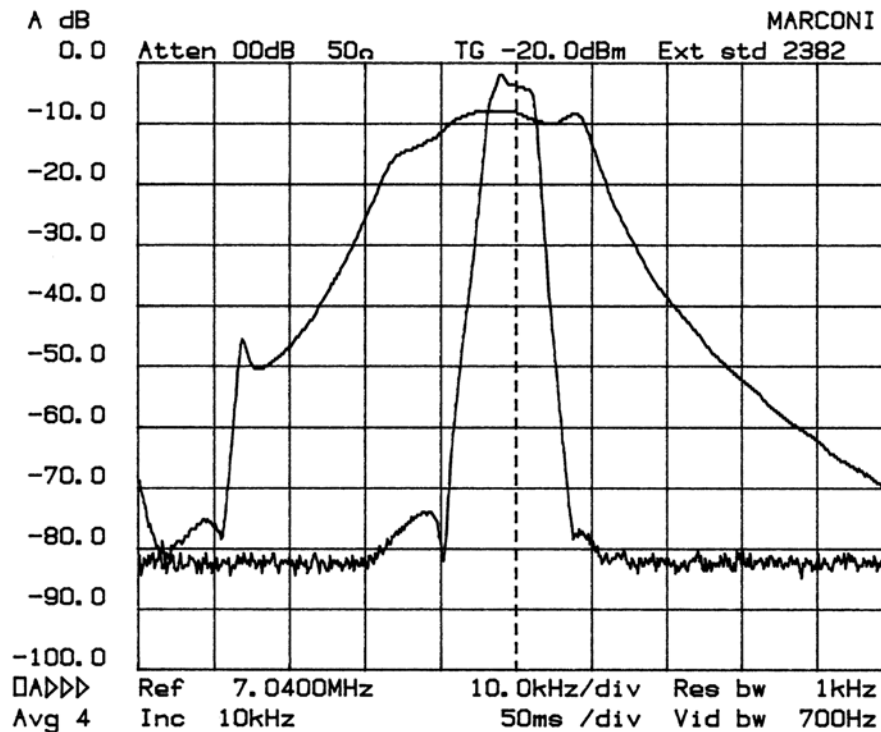

The result of this bandwidth improvement is the reduction of close in intermodulation from multiple signals.

1. What will I notice after installing this mod?

Nothing at first. As you get into crowded band situations you will notice there are more open spaces in the SSB band and less burps and beeps on CW from strong signals.

2. Will this mod allow for wide band SSB, AM and FM reception?

With the main receiver as the overall widest bandwidth of the receiver will be determined by the roofing filter, which is about 5 kHz. This may degrade the audio bandwidth for AM and FM reception somewhat. Those modes will still be available for reception with the sub receiver.

## INSTALLATION INSTRUCTIONS

***Warning: Modern radios contain components which may be damaged by static discharge. Precautions must be taken to eliminate any static electricity buildup between the operator and the radio before any of the internal circuits are touched. If you are not familiar with the proper techniques for this, consult the Radio Amateurs Handbook.***

- \_\_1. Remove the AC line cord from the transceiver.
- \_\_2. Remove the bottom cover.
- \_\_3. Remove the top cover.
- \_\_4. Place the radio bottom side up and locate the IF board. It has the crystal filters on it. Locate J8 in the rear corner near the center of the back panel.
- \_\_5. Remove the coax cable from J8.
- \_\_6. Remove the 6 screws holding the RF board in place. The RF board is the smallest of the three boards on the bottom side of the radio.
- \_\_7. Lift the metal shield can off of the RF board.
- \_\_8. While keeping a sketch of where these cables go, unplug the following coax cables:
  - From J1 and J2 on the PLL board.
  - From J6 and J8 on the RF board.
  - From the Rx Ant In on the rear of the chassis.
- \_\_9. Remove the ribbon cable from the end of the RF board.
- \_\_10. Gently lift the RF board out of the chassis.
- \_\_11. Strip 1/8 inch insulation from the end of a Red, Yellow and Black wire. Tin each end.
- \_\_12. These wires will be tack soldered onto the ribbon connector on the RF board as shown in the photograph and the drawing in Figure 1.
- \_\_13. Return the RF board to it's mounting place, return the cables to the proper connectors, except for the short coax which was in J8 on the IF board.
- \_\_14. Feed the coax that was in J8 through the chassis hole nearby. Also, feed the three colored wires through the hole.
- \_\_15. Turn the radio top side up with the front panel away from you. Remove two screws from the speaker and set it aside.
- \_\_16. The PA unit has a series of fins sticking out the back. Remove three screws holding it in place. One on the back and two on the front of the unit. Do not move the PA unit at this time.

- \_\_17. The Reg unit is to the right and has the AC receptacle on it. Remove the four screws holding it in place. Two are on the back and two are up front. Do not move the Reg unit at this time.

### **Caution Note for the IC 775 Roofing filter installation**

Read this before proceeding with Step 18.

There are two ribbon cables on top of the PA and the TUNER units. The shorter ribbon cable connects the PA unit to the Control unit. This cable has no stress relief and can become disconnected from its socket inside the PA unit when this unit is moved in the following steps. To prevent this, remove the two pieces of tape securing the cable to the top of the TUNER unit. Disconnect the ribbon cable from its connector on the Control unit.

Proceed with steps 19 to 33, then reconnect the ribbon cable and replace the two pieces of tape. PAIHR has provided this information and has detailed pictures of this installation on his web site.

**[HTTP://WWW.REMEEUS.NJENGLISWHAMRADIOIC775ROOFINGFILTER.HTM](http://www.remeeus.njengliswhamradioic775roofingfilter.htm)**

- \_\_18. The shield plate has the grounding wing nut on it. Remove the two screws holding the Shield plate in place.
- \_\_19. Gently push the front end of the Reg unit towards the center of the radio and pull its rear end away from the center of the radio about 1/8 inch. This will free up one end of the shield plate.
- \_\_20. Lift the rear end of the PA unit high enough to remove the shield plate. (About 3/8")
- \_\_21. Prepare the Roofing filter by inserting the four plastic standoffs. Do not remove the safety papers yet.
- \_\_22. Plug the wire from the RF board (See step 14.) into J1 on the Roofing filter.
- \_\_23. Plug the Inrad supplied cable into J2. Be sure the two coax cables are seated well as it will become difficult to insert them after the next few steps. Feed it through the chassis hole to the bottom side.
- \_\_24. Position the Roofing filter in place temporarily as shown in Figure 2. The top of the board should be just below the top of the shield on the PA unit.
- \_\_25. Align one of the standoffs to be in the upper left corner of the right hand shield panel on the PA unit. See figure 2. Remove the safety paper and stick it in place.
- \_\_26. Insert the standoff nearest to J1 on the mod board.
- \_\_27. Remove the safety paper. Align the mod board vertically with the upper standoff and stick in place.
- \_\_28. Remove the mod board by depressing the lock on the standoffs one at a time.
- \_\_29. Insert the two remaining standoffs into the mod board holes and remove the safety papers.
- \_\_30. Align the mod board by putting it on the standoffs which have been previously placed and press into place.

- \_\_31. Prepare the ends of the three colored wires by cutting to length and stripping ¼ inch of insulation. Tin the ends.
- \_\_32. Insert into the terminal board and tighten the screws. Yellow towards the rear of the radio. Red to the center and Black towards the front of the radio.
- \_\_33. Reassemble the PA, PA shield and Regulator units. Removing the lower right from the fan may make the reassembly easier.
- \_\_34. Turn the radio bottom side up and insert the Inrad coax cable into J8 on the IF board.
- \_\_35. Replace the top and bottom covers of the radio.

*International Radio. © 2005. Modifications done at your own risk; seek help if you are not qualified. International Radio Corp. assumes no responsibility for any damages or injuries resulting from improper installation of this modification kit.*

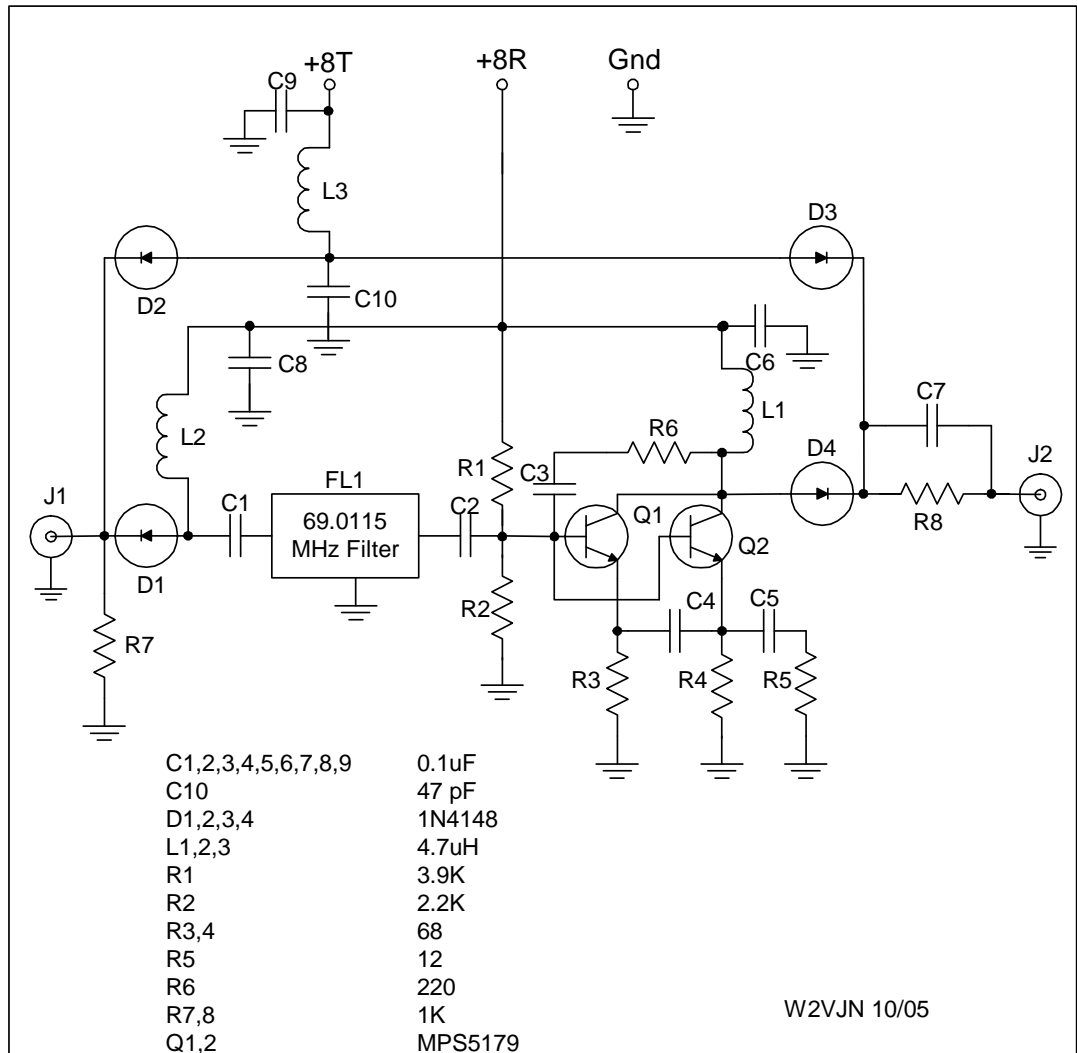

IC 765/775 Roofing Filter Schematic

Parts List:

Assembled Roofing Filter board. (Inrad 118)

8" Coax cable

Four board mounts 561-LAD187

Red, Yellow and Black wires 12" long

Figure 1

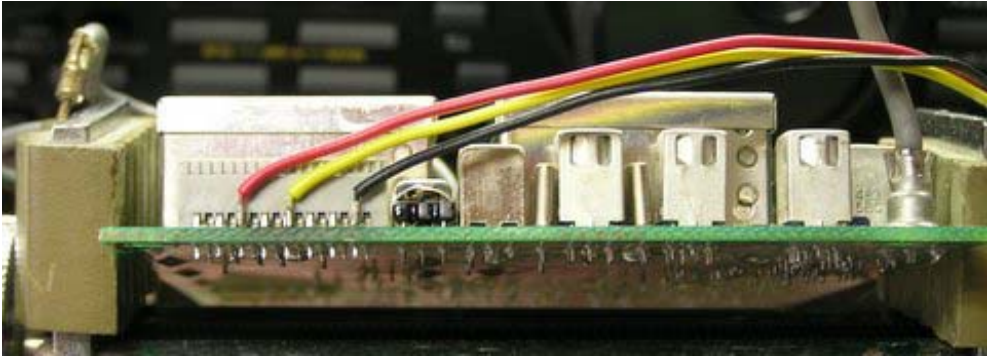

TOP VIEW

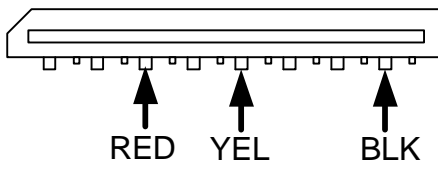

Figure 2

