

IC-765: Installing the Inrad Roofing Filter Mod

The Icom IC-765 roofing filter mod consists of a 6-pole, 4 kHz wide filter followed by a high dynamic range, feedback amplifier. The amplifier provides enough gain to override the filter insertion loss plus a dB or two.

The following plot shows the sweep frequency response of the RF board in an IC-765 radio. The wider curve is the OEM response, and the narrow curve is with the Inrad roofing filter mod added. In the IC-765, the most important part of the roofing filter characteristic is from the pass band down about 35 or 40 dB on each side.

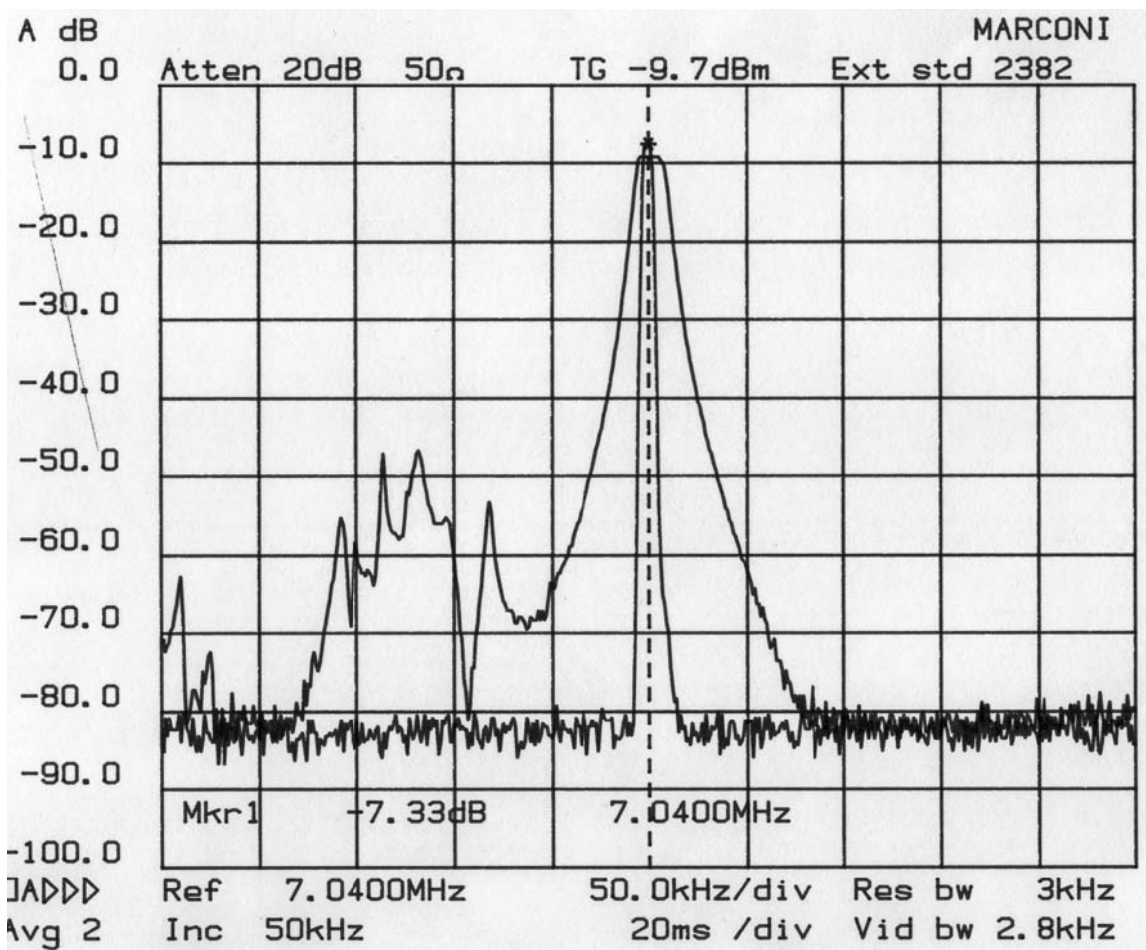

The result of the bandwidth improvement shown above is the reduction of close-in intermodulation from multiple signals. The IMD dynamic range can be improved 10 dB or more for some signal spacings. The main receiver

audio response is reduced about 100 Hz in the SSB mode. Operating the noise blanker does not result in as much degradation of the dynamic range.

1. What can you expect from this mod?

Less IMD in crowded band conditions, particularly from stations at offset frequencies of 2 to 10 kHz on either side of the operating frequency.

2. Will it defeat the noise blanker?

No, the roofing filter is in the circuit before the noise blanker sample is taken. The filter delay is added to both signal and noise. Since less noise and fewer strong signals are able to reach the noise blanker, it actually improves its operation.

3. Will this mod allow for wide band SSB, AM and FM reception?

No, because the overall widest bandwidth of the receiver is determined by the roofing filter, which is about 5 kHz. Normal 2400 Hz SSB is not affected.

Description of Operation

The Roofing filter mod inserts a narrow-band crystal filter in between the RF assembly and the IF or Main board. An amplifier is included to compensate for the filter loss and to provide a small amount of excess gain. Reducing the bandwidth at this point in the radio helps to keep strong off-frequency signals out of the second mixer where they can cause intermodulation. The excess gain slightly improves the noise floor of the radio. During transmit operation, the amplifier and filter are removed to allow the signal to pass in the other direction from the IF to the RF assembly.

Installation Instructions

Warning: *Modern radios contain components which may be damaged by static discharge. Precautions must be taken to eliminate any static electricity buildup between the operator and the radio before any of the internal circuits are touched. If you are not familiar with the proper techniques for this, consult the Radio Amateurs Handbook.*

1. Remove the AC line cord from the transceiver.
2. Remove the bottom cover.
3. Insert the two standoff mounts into the holes in the 765 Roofing mod. They should extend below the opposite side from the components. Do not remove the paper from the mounts yet.

4. With the front panel facing you, the RF unit shield is on the right side and the Main unit PC board is on the left. Locate J7 in the right-front corner of the Main unit.
5. Remove the coax plug from J7 and insert it into J1 of the 765 Roofing mod.
6. Locate a position where the Roofing mod will fit between the RF unit shield and the Main unit PC board while not over stressing the coax cable.

Note: You may need to cut some tie wraps and move the multi-wire cable out of the way. See the photo.

7. Remove the paper from the plastic board mounts one at a time and carefully put the mod in place when you are satisfied that the mod will fit well.
8. Locate W114, a short wire connecting two holes together on the PC board. See the photo. A magnifying glass can help.
9. Strip $\frac{1}{4}$ inch of insulation from the ends on the red wire and tin.
10. Bend the tinned end of the red wire to a right angle and solder it carefully to W114.
11. Insert the other end of the red wire into the center hand terminal of the terminal strip on the mod and tighten the screw.
12. Locate W72, a short wire connecting two holes together on the PC board. See the photo. A magnifying glass can help.
13. Strip $\frac{1}{4}$ inch of insulation from the ends on the yellow wire and tin.
14. Bend the tinned end of the yellow wire to a right angle and solder it carefully to W72.
15. Insert the other end of the yellow wire into the left-hand terminal of the terminal strip on the mod and tighten the screw. See the photo.
16. Mount the solder lug under the board-mounting screw just to the left of the mod, as shown in the photo.
17. Strip $\frac{1}{4}$ inch of insulation from the ends on the black wire and tin.
18. Insert one end of the black wire into the right-hand terminal of the terminal strip on the mod and tighten the screw.
19. Form a hook on the other end and solder it to the solder lug.

20. Insert one end of the supplied coax cable into J2 of the mod.
21. Insert the other end of the coax cable into J7 on the Main-unit PC board.
22. Wrap the coax and multiwire cable together with the supplied tie wraps.
Do not make them too tight.
23. This completes the installation. Replace the bottom cover of the radio.

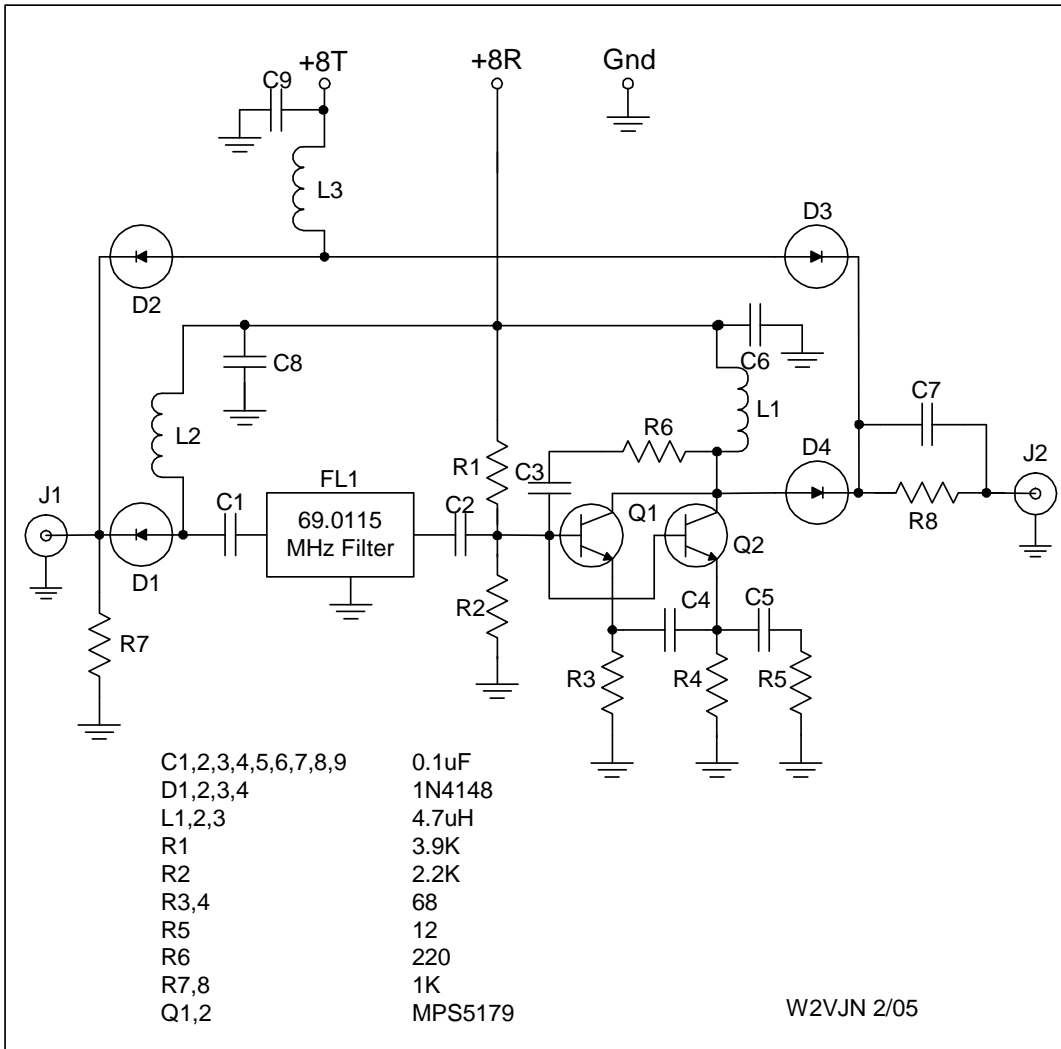

IC 765 Roofing Filter Schematic

PARTS LIST

- Assembled Roofing Filter board (Inrad 118)**
- Coax cable 8"**
- 2 Board mounts**
- Red and Yellow wire-12" each**
- Black wire 6"**
- Solder lug**

IC 765 INSTALLATION

YELLOW to W 72

RED to W 114



AREA OF DETAIL

BLACK to RIGHT Terminal
RED to CENTER Terminal
YELLOW to LEFT Terminal

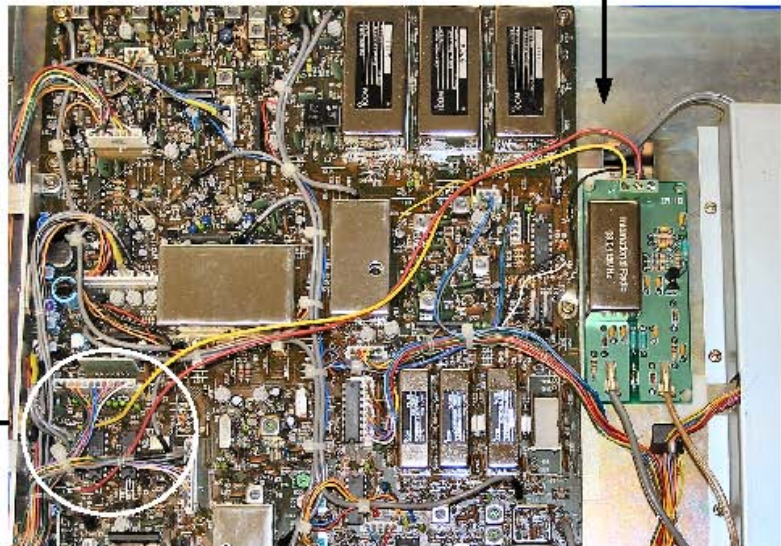

FRONT PANEL